

Symmetric Bending of Beams

- A beam is any long structural member on which loads act perpendicular to the longitudinal axis.



Learning objectives

- Understand the theory, its limitations and its applications for strength based design and analysis of symmetric bending of beams.
- Develop the discipline to visualize the normal and shear stresses in symmetric bending of beams.

6.5 Due to the action of the external moment M_z and force P , the rigid plate shown in Fig. P6.5 was observed to rotate by 2° and the normal strain in bar 1 was found $\epsilon_1 = 2000 \mu \text{ in/in}$. Both bars have an area of cross-section of $A = 1/2 \text{ in}^2$ and a Modulus of Elasticity of $E = 30,000 \text{ ksi}$. Determine the applied moment M_z and force P .

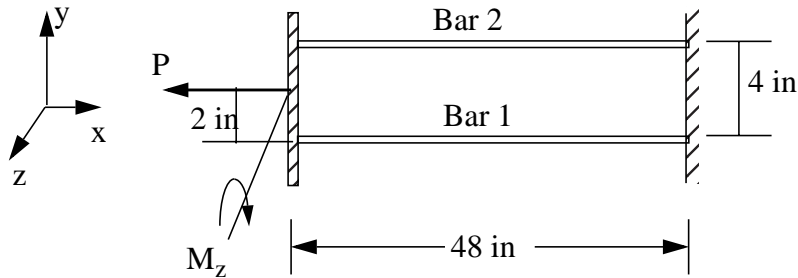
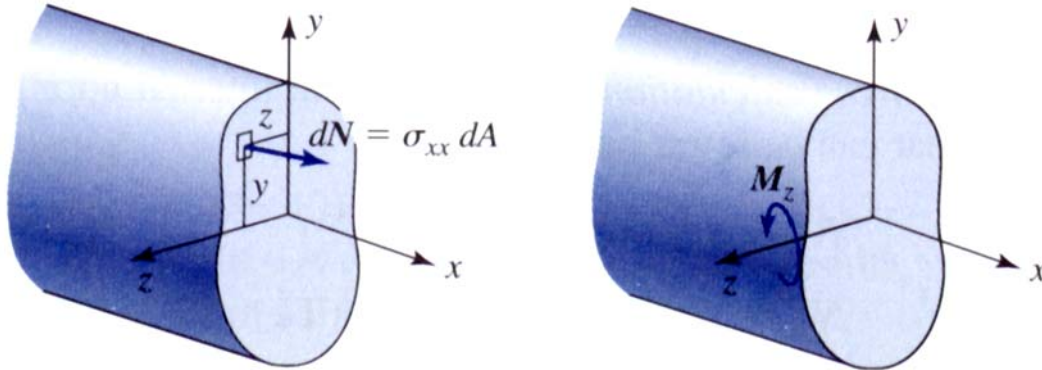

Fig. P6.5

Internal Bending Moment



$$M_z = - \int_A y \sigma_{xx} dA$$

$$\int_A \sigma_{xx} dA = 0$$

- Above equations **are independent of material model** as these equations represents **static equivalency** between the normal stress on the entire cross-section and the internal moment.
- The line on the cross-section where the bending normal stress is zero is called the neutral axis.
- Location of neutral axis is chosen to satisfy $\int_A \sigma_{xx} dA = 0$.
- Origin of y is always at the neutral axis, irrespective of the material model.

6.8 Steel ($E_{\text{steel}} = 30,000$ ksi) strips are securely attached to a wooden ($E_{\text{wood}} = 2,000$ ksi) beam as shown below. The normal strain at the cross-section due to bending about the z -axis is $\epsilon_{xx} = -100y \mu$ where y is measured in inches, and the dimensions of the cross-section are $d = 2$ in, $h_W = 4$ in and $h_S = (1/8)$ in. Determine the equivalent internal moment M_z .

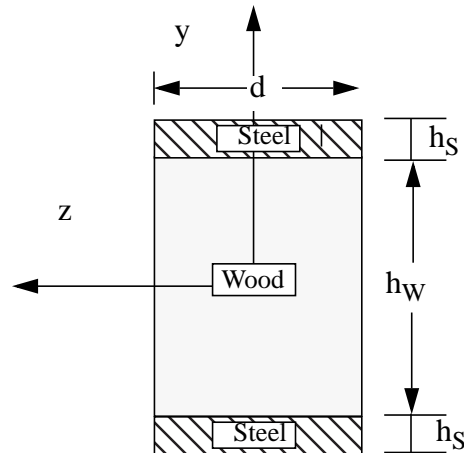

Theory of symmetric bending of beams

Limitations

- The length of the member is significantly greater than the greatest dimension in the cross-section.
- We are away from the regions of stress concentration.
- The variation of external loads or changes in the cross-sectional areas are gradual except in regions of stress concentration.
- The cross-section has a plane of symmetry.
- The loads are in the plane of symmetry.
- The load direction does not change with deformation.
- The external loads are not functions of time.

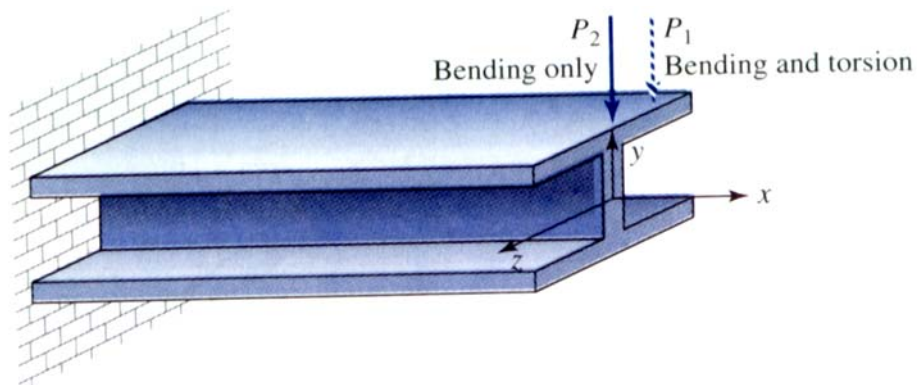

Theory objectives:

- To obtain a formula for the bending normal stress σ_{xx} , and bending shear stress τ_{xy} in terms of the internal moment M_z and the internal shear force V_y .
- To obtain a formula for calculation of the beam deflection $v(x)$.

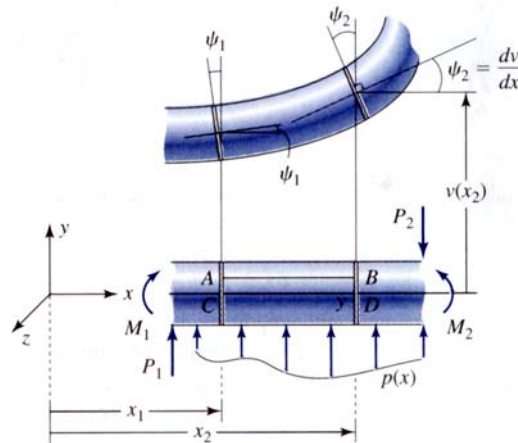

The distributed force $p(x)$, has units of force per unit length, and is considered positive in the positive y -direction.

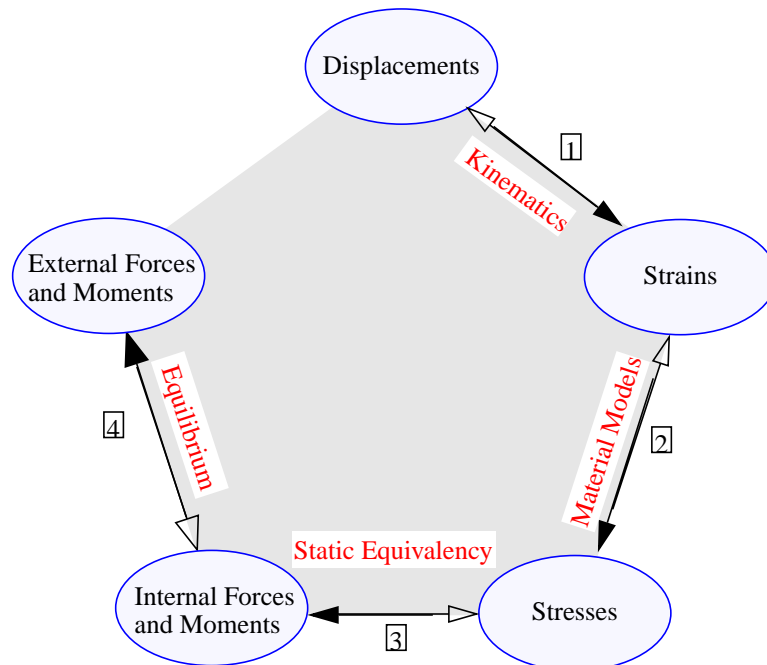

Kinematics

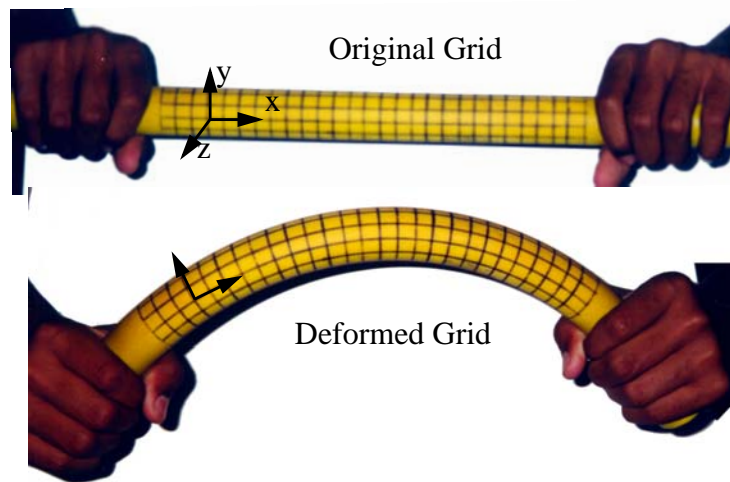

Assumption 1 Squashing, i.e., dimensional changes in the y -direction, is significantly smaller than bending.

$$\left(\varepsilon_{yy} = \frac{\partial v}{\partial y} \approx 0 \right) \Rightarrow v = v(x)$$

Assumption 2 Plane sections before deformation remain plane after deformation. $u = u_o - \psi y$

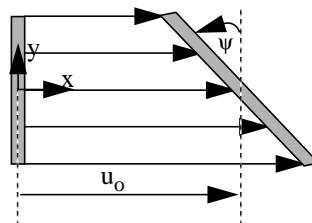

Assumption 3 Plane perpendicular to the beam axis remain **nearly** perpendicular after deformation. $\gamma_{xy} \approx 0$.

Assumption 4 Strains are small. $\tan \psi \approx \psi = \frac{dv}{dx}$

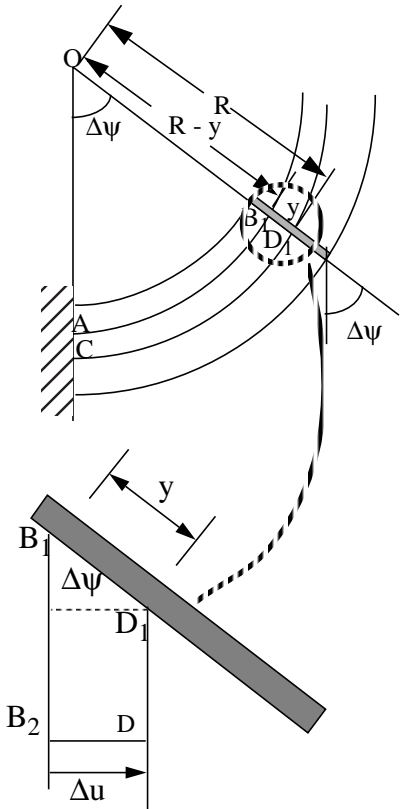

Method I

$$AB = CD = CD_1$$

$$\epsilon_{xx} = \frac{AB_1 - AB}{AB} = \frac{(R - y)\Delta\psi - R\Delta\psi}{R\Delta\psi}$$

$$\epsilon_{xx} = -\frac{y}{R}$$

Method II

$$\Delta u = -y \sin \Delta\psi \approx -y\Delta\psi$$

$$\epsilon_{xx} = \lim_{\Delta x \rightarrow 0} \left(\frac{\Delta u}{\Delta x} \right) = -y \frac{d\psi}{dx} = -y \frac{d^2 v}{dx^2}(x)$$

$$\epsilon_{xx} = -y \frac{d^2 v}{dx^2}(x)$$

- bending normal strain ϵ_{xx} varies linearly with y and has maximum value at either the top or the bottom of the beam.
- $\frac{1}{R} = \frac{d^2 v}{dx^2}(x)$ is the curvature of the deformed beam and R is the radius of curvature of the deformed beam.

Material Model

- Assumption 5 Material is isotropic.
- Assumption 6 Material is linearly elastic.
- Assumption 7 There are no inelastic strains.

From Hooke's Law: $\sigma_{xx} = E\epsilon_{xx}$, we obtain $\sigma_{xx} = -Ey \frac{d^2 v}{dx^2}(x)$

Location of neutral axis

$$\int_A \sigma_{xx} dA = 0 \text{ or } \int_A -Ey \frac{d^2 v}{dx^2}(x) dA = 0 \text{ or } \int_A Ey dA = 0$$

Assumption 8 Material is homogenous across the cross-section of the beam.

$$\int_A y dA = 0$$

- Neutral axis i.e, the origin, is at the centroid of the cross-section constructed from linear-elastic, isotropic, homogenous material.
- The axial problem and bending problem are de-coupled if the origin is at the centroid for linear-elastic, isotropic, homogenous material
- bending normal stress σ_{xx} varies **linearly with y** and is zero at the centroid.
- bending normal stress σ_{xx} is maximum at a point farthest from the neutral axis (centroid).

6.20 The cross-section of a beam with a coordinate system that has an origin at the centroid C of the cross-section is shown. The normal strain at point A due to bending about the z -axis, and the Modulus of Elasticity are as given.

- Plot the stress distribution across the cross-section.
- Determine the maximum bending normal stress in the cross-section.
- Determine the equivalent internal bending moment M_z by integration.

$$\epsilon_{xx} = 200 \mu$$

$$E = 8000 \text{ ksi}$$

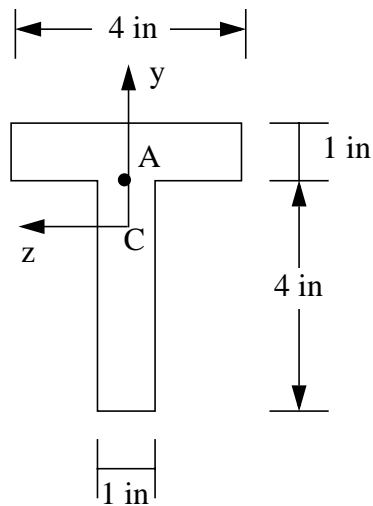

Sign convention for internal bending moment

$$M_z = - \int_A y \sigma_{xx} dA$$

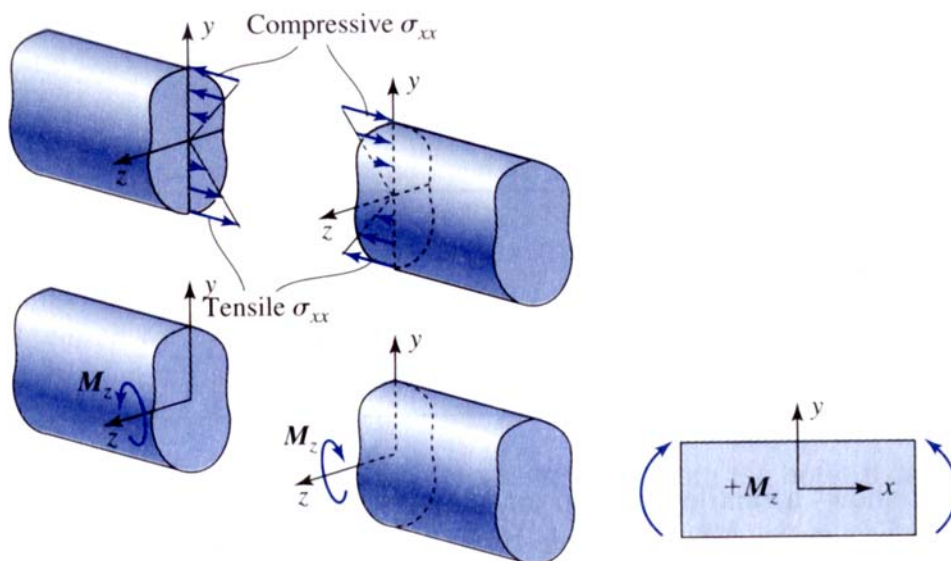
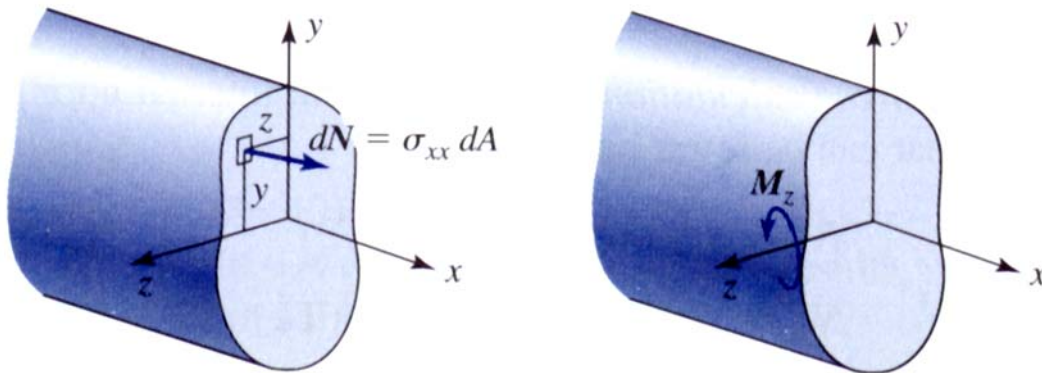

- The direction of positive internal moment M_z on a free body diagram must be such that it puts a point in the positive y direction into compression.

Sign convention for internal shear force

Internal Forces and Moment necessary for equilibrium

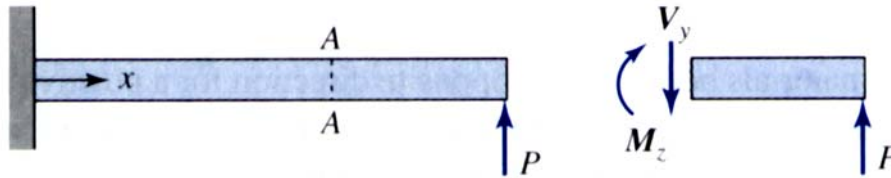

- Recall Assumption 3: Plane perpendicular to the beam axis remain **nearly** perpendicular after deformation. $\gamma_{xy} \approx 0$.
- From Hooke's Law: $\tau_{xy} = G\gamma_{xy}$
- Bending shear stress is small but not zero.
- Check on theory: The maximum bending normal stress σ_{xx} in the beam should be nearly an order of magnitude greater than the maximum bending shear stress τ_{xy} .

$$V_y = \int_A \tau_{xy} dA$$

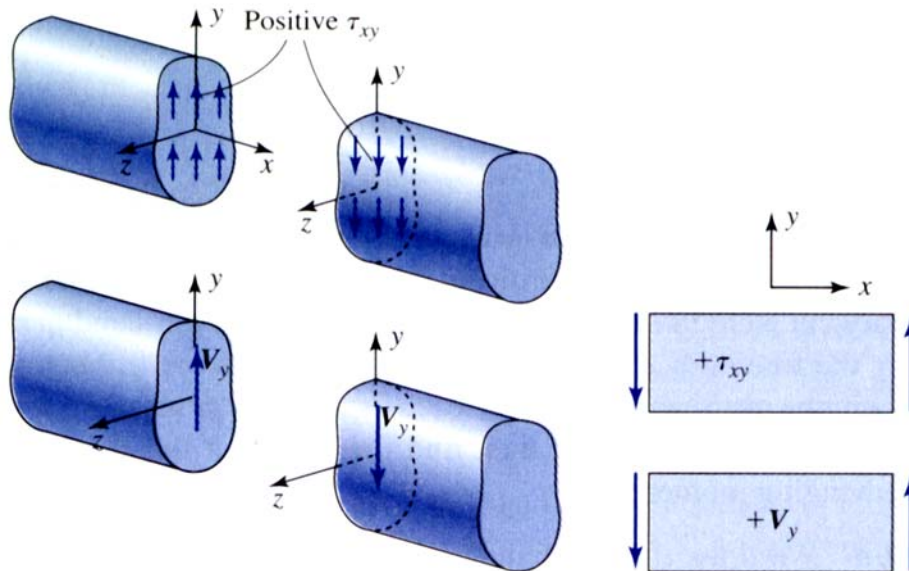

- The direction of positive internal shear force on a free body diagram is in the direction of positive shear stress on the surface.

6.26 A beam and loading in three different coordinate system is shown. Determine the internal shear force and bending moment at the section containing point A for the three cases shown using the sign convention described in Section 6.2.5.

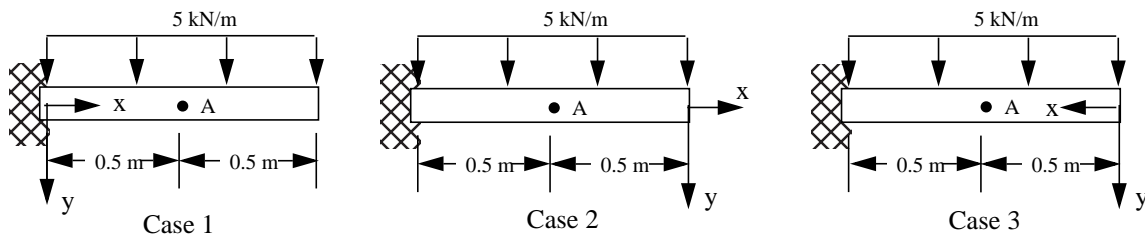

Flexure Formulas

$$\sigma_{xx} = -Ey \frac{d^2 v}{dx^2}(x)$$

$$M_z = -\int_A y \sigma_{xx} dA = -\int_A y \left[-Ey \frac{d^2 v}{dx^2}(x) \right] dA = \frac{d^2 v}{dx^2}(x) \left(\int_A Ey^2 dA \right)$$

For homogenous cross-sections

- Moment-curvature equation: $M_z = EI_{zz} \frac{d^2 v}{dx^2}$
- I_{zz} is the second area moment of inertia about z-axis.
- The quantity EI_{zz} is called the bending rigidity of a beam cross-section.
- Flexure stress formula: $\sigma_{xx} = -\left(\frac{M_z y}{I_{zz}} \right)$

Two options for finding M_z

- On a free body diagram M_z is drawn as per the sign convention irrespective of the loading.
 - positive values of stress σ_{xx} are tensile
 - negative values of σ_{xx} are compressive.
- On a free body diagram M_z is drawn at the imaginary cut in a direction to equilibrate the external loads.
 - The tensile and compressive nature of σ_{xx} must be determined by inspection.

6.20 The cross-section of a beam with a coordinate system that has an origin at the centroid C of the cross-section is shown. The normal strain at point A due to bending about the z -axis, and the Modulus of Elasticity are as given.

(d) Determine the equivalent internal bending moment M_z by flexure formula.

$$\epsilon_{xx} = 200 \mu$$

$$E = 8000 \text{ ksi}$$

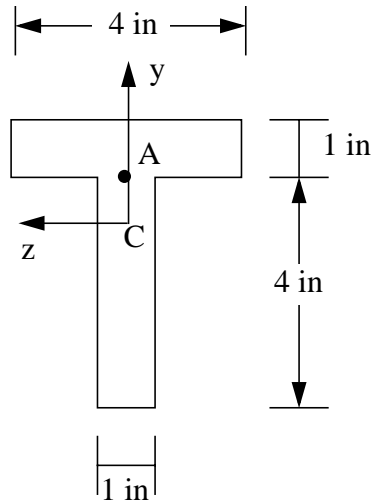

Class Problem 1

The bending normal stress at point B is 15 ksi.

- (a) Determine the maximum bending normal stress on the cross-section.
(b) What is the bending normal strain at point A if $E = 30,000$ ksi.

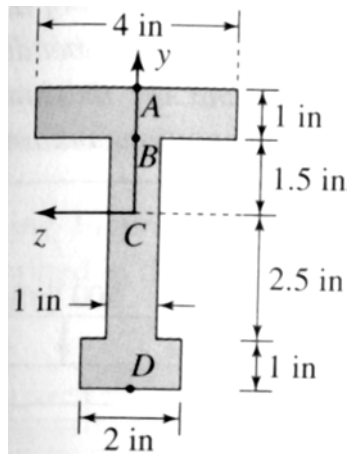

6.15 Fig. P6.15(a) shows four separate wooden strips that bend independently about the neutral axis passing through the centroid of each strip. Fig. P6.15(b) shows the four strips are glued together and bend as a unit about the centroid of the glued cross-section. (a) Show that $I_G = 16I_S$, where I_G is the area moment of inertias for the glued cross-section and I_S is the total area moment of inertia of the four separate beams. (b) Also show $\sigma_G = \sigma_S/4$, where σ_G and σ_S are the maximum bending normal stress at any cross-section for the glued and separate beams, respectively.

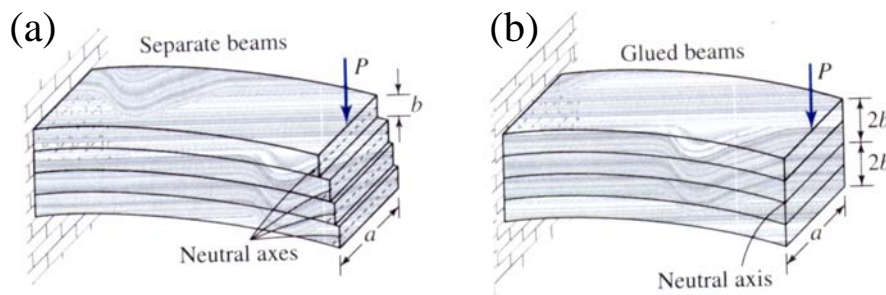
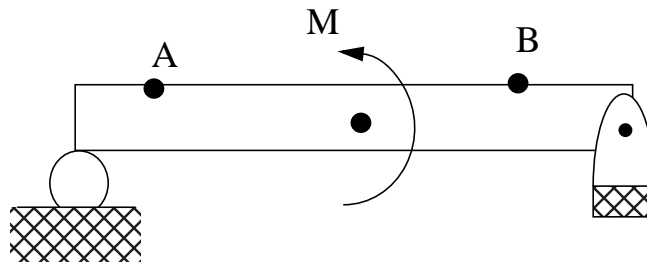

Fig. P6.15

6.30 For the beam and loading shown, draw an approximate deformed shape of the beam. By inspection determine whether the bending normal stress is tensile or compressive at points A and B.



Class Problem 2

6.34 For the beam and loading shown, draw an approximate deformed shape of the beam. By inspection determine whether the bending normal stress is tensile or compressive at points A and B.

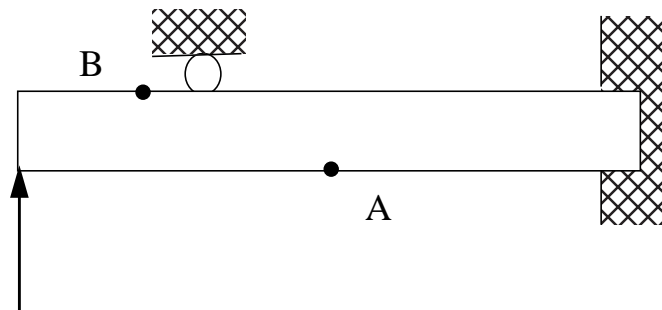

6.41 The beam, loading and the cross-section of the beam are as shown. Determine the bending normal stress at point A and the maximum bending normal stress in the section containing point A

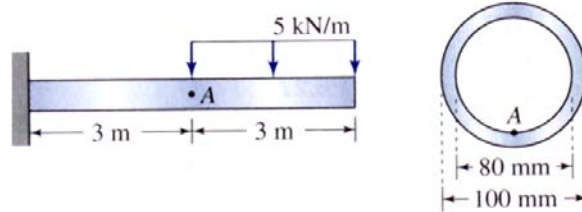

6.46 A wooden ($E = 10 \text{ GPa}$) rectangular beam, loading and cross-section are as shown in Fig. P6.46. The normal strain at point A in Fig. P6.46 was measured as $\epsilon_{xx} = -600 \mu$. Determine the distributed force w that is acting on the beam.

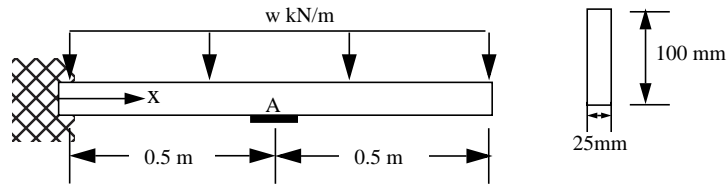
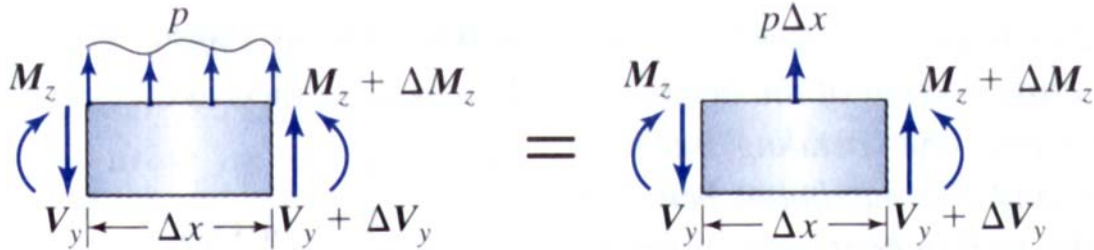

Fig. P6.46

Shear and Moment by Equilibrium



Differential Beam Element

Differential Equilibrium Equations: $\frac{dV_y}{dx} = -p$ $\frac{dM_z}{dx} = -V_y$

- The above equilibrium equations are applicable at all points on the beam except at points where there is a point (concentrated) force or point moment.

Two Options for finding V_y and M_z as a function of x

- Integrate equilibrium equations and find integration constants by using boundary conditions or continuity conditions. This approach is preferred if p **not** uniform or linear.
- Make an imaginary cut at some location x , draw free body diagram and use static equilibrium equations to find V_y and M_z . Check results using the differential equilibrium equations above. This approach is preferred if p **is** uniform or linear.

6.51 (a) Write the equations for shear force and bending moments as a function of x for the entire beam. (b) Show your results satisfy the differential equilibrium equations.

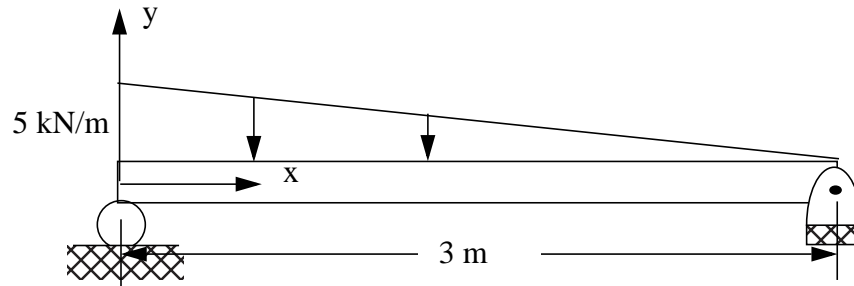

6.58 For the beam shown in Fig. P6.58, (a) write the shear force and moment equation as a function of x in segment CD and segment DE. (b) Show that your results satisfy the differential equilibrium equations. (c) What are the shear force and bending moment value just before and just after point D.

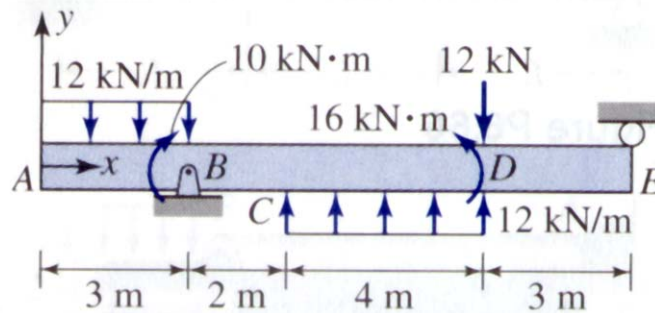

Fig. P6.58

Class Problem 3

Write the shear force and moment equation as a function of x in segment AB.

Shear and Moment Diagrams

- Shear and Moment diagrams are a plots of internal shear force V_y and internal bending moment M_z vs. x .

Distributed force

- An integral represent area under the curve.
- To avoid subtracting positive areas and adding negative areas, define $V = -V_y$

$$V_2 = V_1 + \int_{x_1}^{x_2} p dx \qquad M_2 = M_1 + \int_{x_1}^{x_2} V dx$$

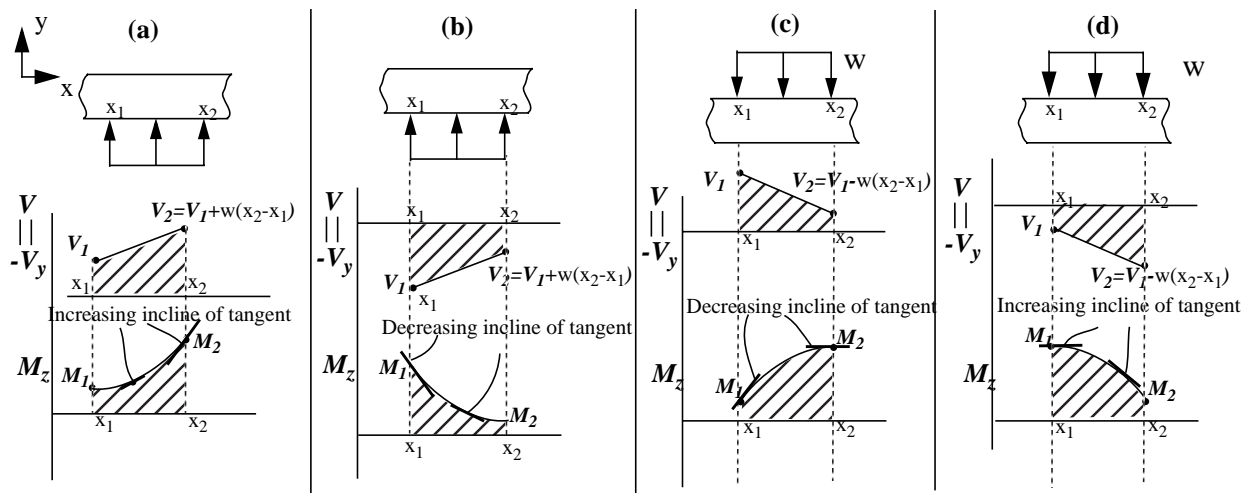

- If V_y is linear in an interval then M_z will be a quadratic function in that interval.
- Curvature rule for quadratic M_z curve.

The curvature of the M_z curve must be such that the incline of the tangent to the M_z curve must increase (or decrease) as the magnitude of the V increases (or decreases).

or

The curvature of the moment curve is concave if p is positive, and convex if p is negative.

Point Force and Moments

- Internal shear force jumps by the value of the external force as one crosses the external force from left to right.
- Internal bending moment jumps by the value of the external moment as one crosses the external moment from left to right.
- Shear force & moment templates can be used to determine the direction of the jump in V and M_z .

A template is a free body diagram of a small segment of a beam created by making an imaginary cut just before and just after the section where the a point external force or moment is applied.

Shear Force Template

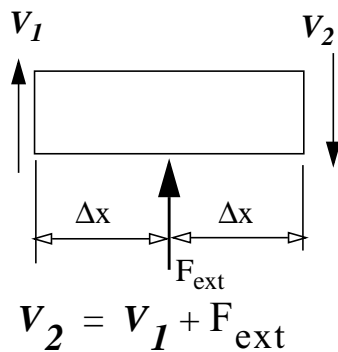

Moment Template

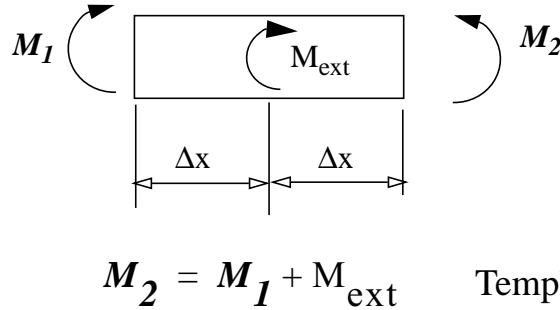

Template Equations

- The jump in V is in the direction of F_{ext}

6.70 Draw the shear and moment diagram and determine the values of maximum shear force V_y and bending moment M_z .

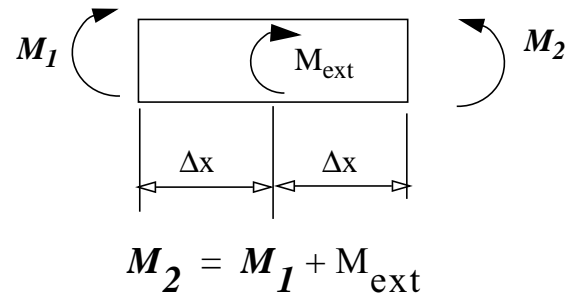
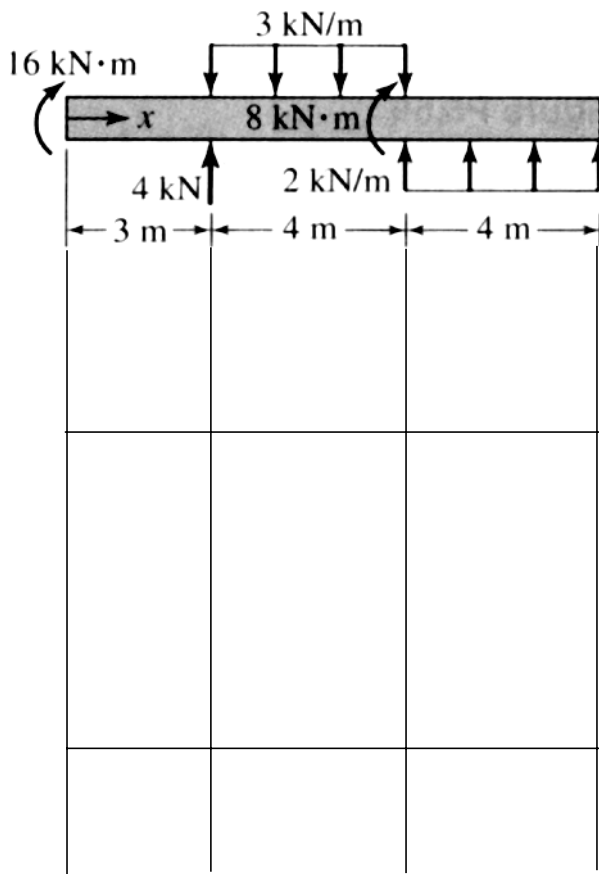

6.77 Two pieces of lumber are glued together to form the beam shown Fig. P6.77. Determine the intensity w of the distributed load, if the maximum tensile bending normal stress in the glue is limited to 800 psi (T) and maximum bending normal stress in wood is limited to 1200 psi.

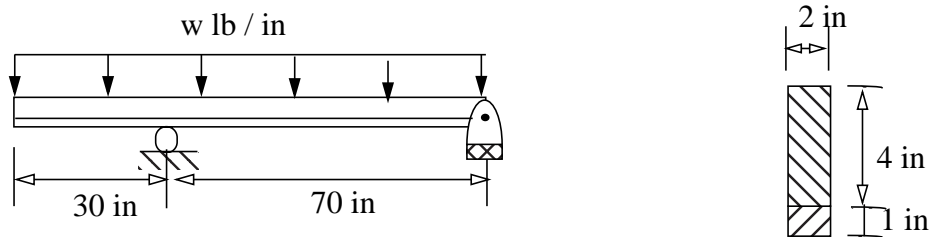
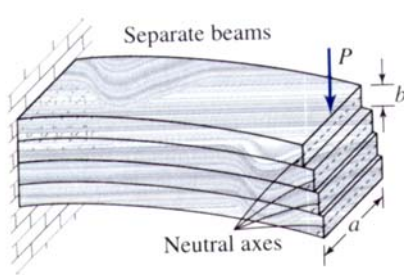

Fig. P6.77

Shear Stress in Thin Symmetric Beams

- Recollect problem 6-15 for motivation for gluing beams



$$I_G = 16I_S$$

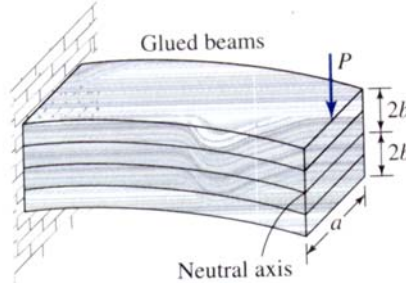

$$\sigma_G = \sigma_S/4$$

-

Separate Beams



Relative Sliding

Glued Beams



No Relative Sliding

- Assumption of plane section perpendicular to the axis remain perpendicular during bending requires the following limitation.

Maximum bending shear stress must be an order of magnitude less than maximum bending normal stress.

Shear stress direction

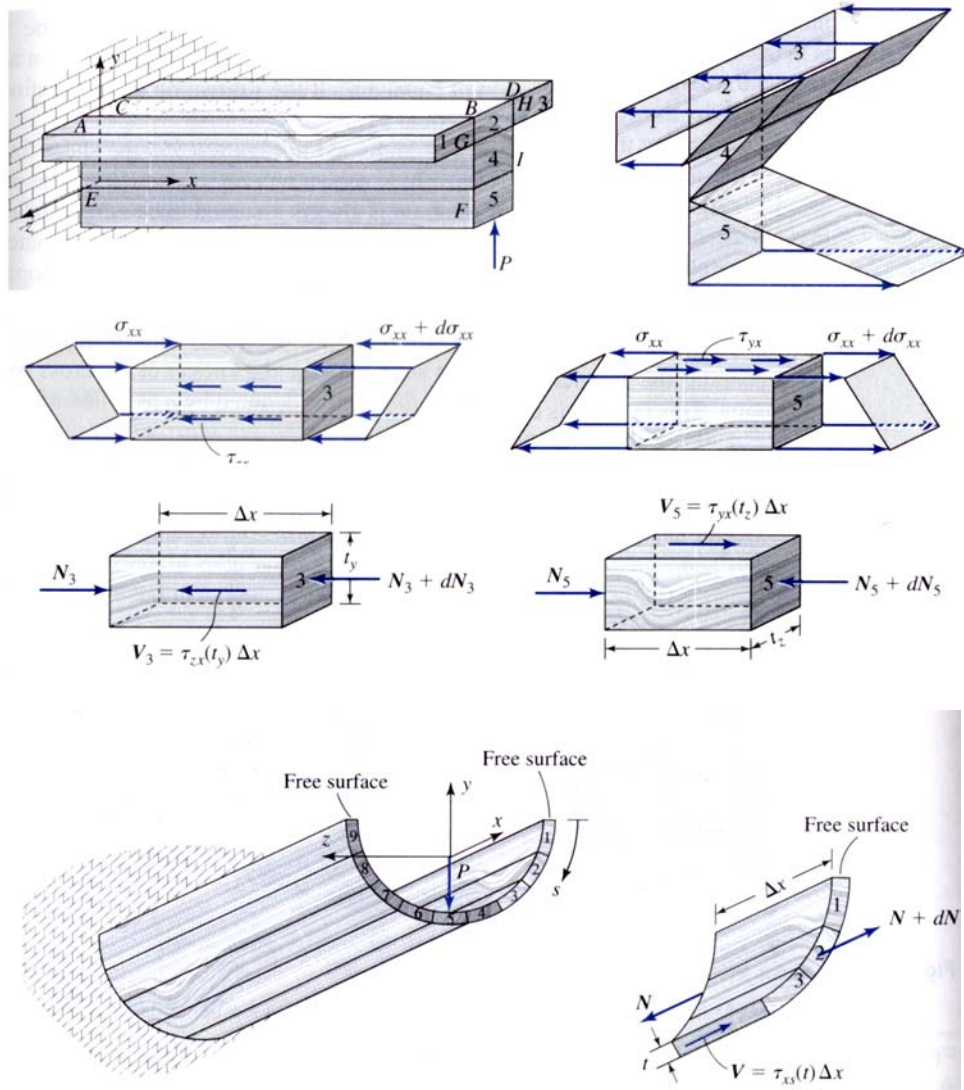

Shear Flow: $q = \tau_{xs}t$

- The units of shear flow 'q' are **force per unit length**.

The shear flow along the center-line of the cross-section is drawn in such a direction as to satisfy the following rules:

- the resultant force in the y-direction is in the same direction as V_y .
- the resultant force in the z-direction is zero.
- it is symmetric about the y-axis. This requires shear flow will change direction as one crosses the y-axis on the center-line.

6.88 Assuming a positive shear force V_y (a) sketch the direction of the shear flow along the center-line on the thin cross-sections shown.(b) At points A, B, C, and D, determine if the stress component is τ_{xy} or τ_{xz} and if it is positive or negative.

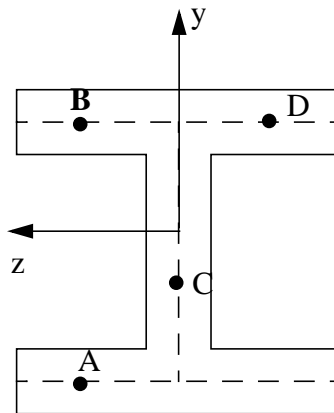

Class Problem 4

6.90 Assuming a positive shear force V_y (a) sketch the direction of the shear flow along the center-line on the thin cross-sections shown.(b) At points A, B, C, and D, determine if the stress component is τ_{xy} or τ_{xz} and if it is positive or negative.

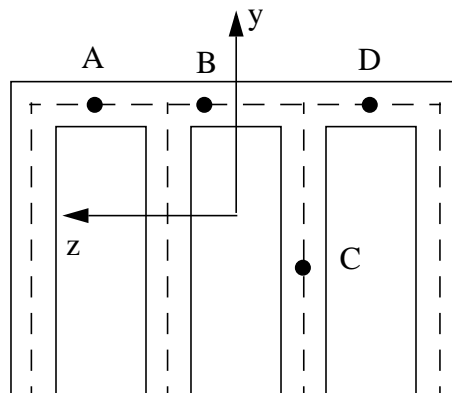

Bending Shear Stress Formula

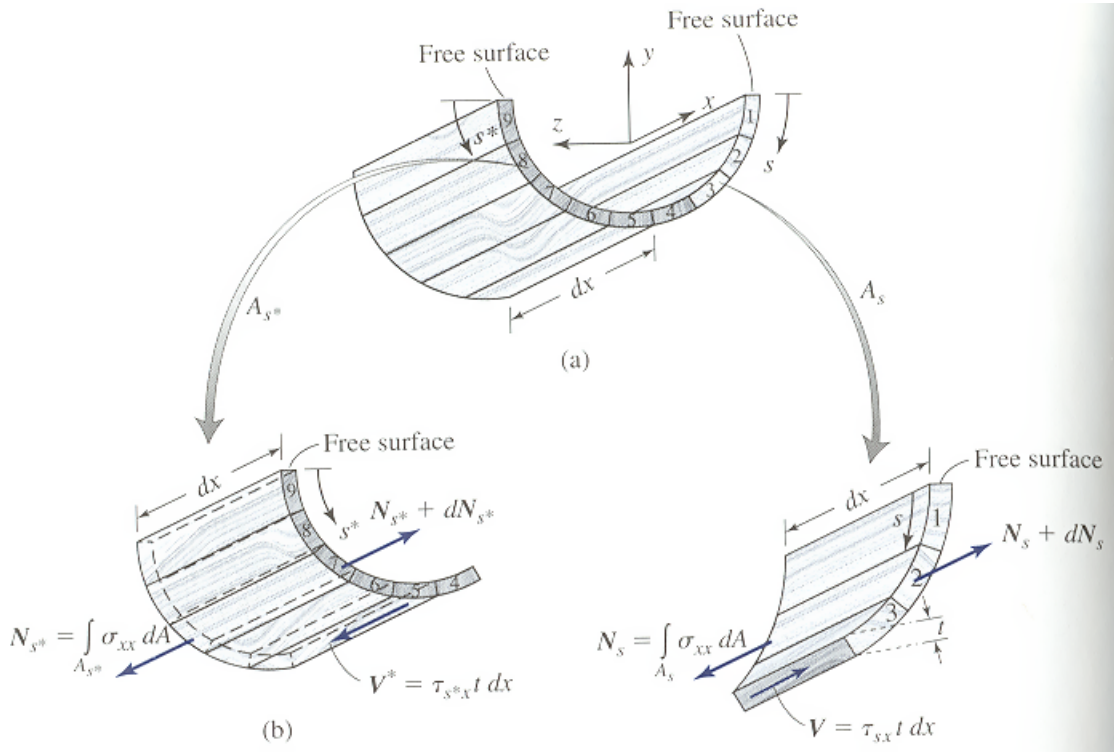

$$(N_s + dN_s) - N_s + \tau_{sx} t dx = 0 \qquad \tau_{sx} t = - \frac{dN_s}{dx}$$

$$\tau_{sx} t = - \frac{d}{dx} \int_{A_s} \sigma_{xx} dA = - \frac{d}{dx} \int_{A_s} \left(- \frac{M_z y}{I_{zz}} \right) dA = \frac{d}{dx} \left[\frac{M_z}{I_{zz}} \int_{A_s} y dA \right]$$

- A_s is the area between the free surface and the point where shear stress is being evaluated.

Define: $Q_z = \int_{A_s} y dA$ $\tau_{sx} t = \frac{d}{dx} \left[\frac{M_z Q_z}{I_{zz}} \right]$

Assumption 9 **The beam is not tapered.**

$$q = t \tau_{sx} = \left(\frac{Q_z}{I_{zz}} \right) \frac{dM_z}{dx} = - \left(\frac{Q_z V_y}{I_{zz}} \right) \qquad \boxed{\tau_{sx} = \tau_{xs} = - \left(\frac{V_y Q_z}{I_{zz} t} \right)}$$

Calculation of Q_z

$$Q_z = \int_{A_s} y dA$$

- A_s is the area between the free surface and the point where shear stress is being evaluated.
- Q_z is zero at the top surface as the enclosed area A_s is zero.
- Q_z is zero at the bottom surface ($A_s=A$) by definition of centroid.

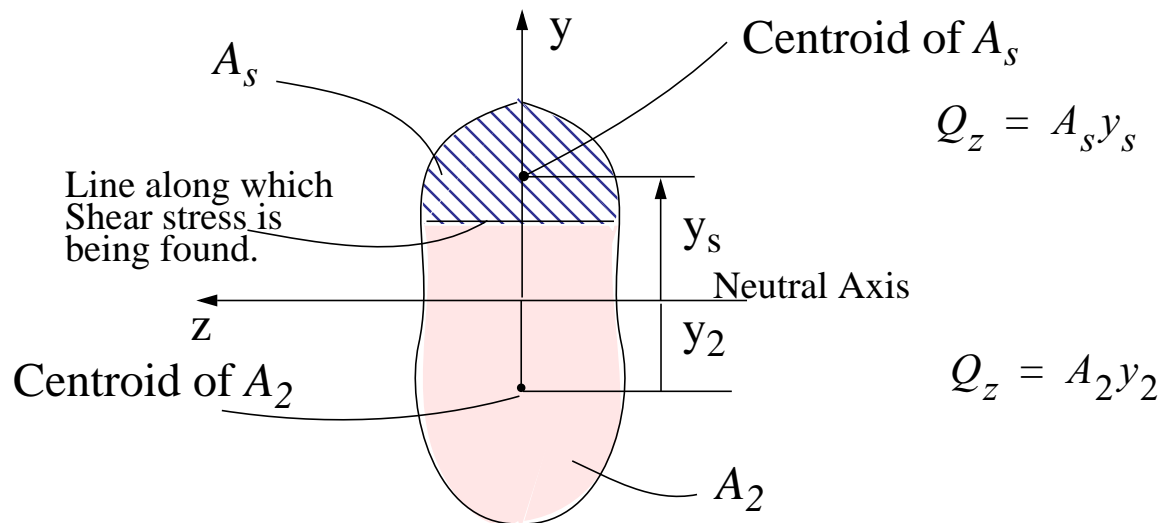

- Q_z is maximum at the neutral axis.
- Bending shear stress at a section is maximum at the neutral axis.

Bending stresses and strains

Top or
Bottom

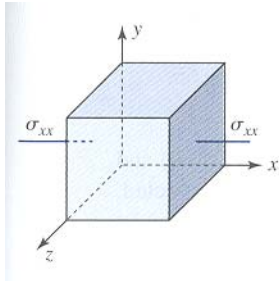

Neutral
Axis

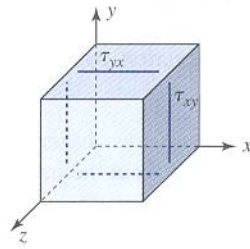

Point in
Web

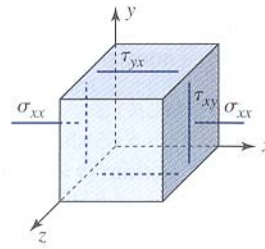

Point in
Flange

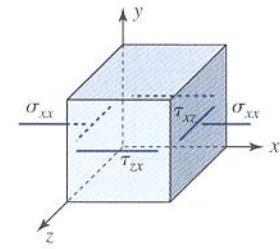

$$\epsilon_{xx} = \frac{\sigma_{xx}}{E}$$

$$\epsilon_{yy} = -\left(\frac{\nu\sigma_{xx}}{E}\right) = -\nu\epsilon_{xx}$$

$$\epsilon_{zz} = -\left(\frac{\nu\sigma_{xx}}{E}\right) = -\nu\epsilon_{xx}$$

$$\gamma_{xy} = \frac{\tau_{xy}}{G}$$

$$\gamma_{xz} = \frac{\tau_{xz}}{G}$$

6.97 For the beam, loading and cross-section shown, determine: (a) the magnitude of the maximum bending normal and shear stress. (b) the bending normal stress and the bending shear stress *at point A*. Point A is on the cross-section 2 m from the right end. Show your result on a stress cube. The area moment of inertia for the beam was calculated to be $I_{zz} = 453 (10^6) \text{ mm}^4$.

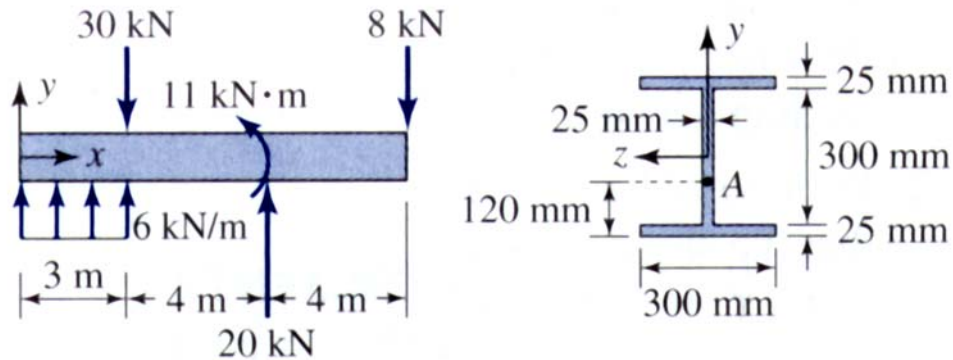

Shear Flow

$$q = -\left(\frac{V_y Q_z}{I_{zz}}\right)$$

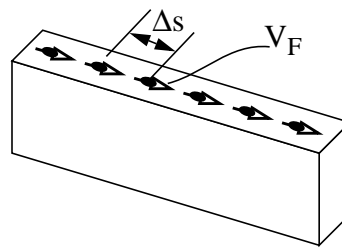
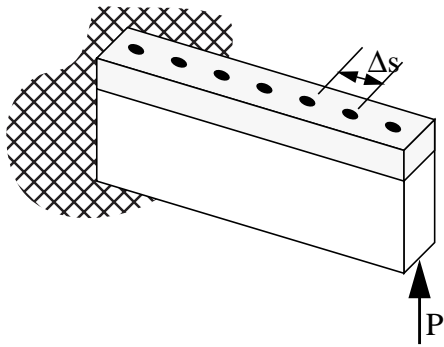

$$q = V_F / \Delta s$$

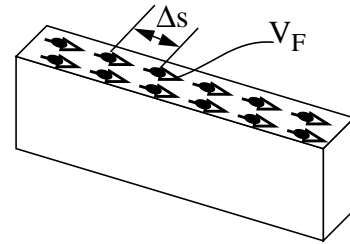

$$q = 2V_F / \Delta s$$

6.104 A wooden cantilever box beam is to be constructed by nailing four 1 inch x 6 inch pieces of lumber in one of the two ways shown. The allowable bending normal and shear stress in the wood are 750 psi and 150 psi, respectively. The maximum force that the nail can support is 100 lbs. Determine the maximum value of load P to the nearest pound, the spacing of the nails to the nearest half inch, and the preferred nailing method.*

Joining Method 1

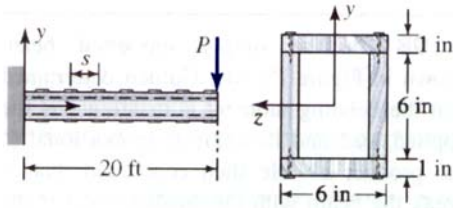

Joining Method 2

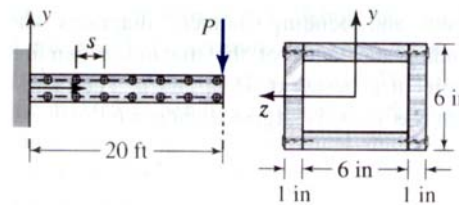

6.115 A cantilever, hollow-circular aluminum beam of 5 feet length is to support a load of 1200-lbs. The inner radius of the beam is 1 inch. If the maximum bending normal stress is to be limited to 10 ksi, determine the minimum outer radius of the beam to the nearest 1/16th of an inch.