

Document Title		Page No.	1/ 28
Document No.		Revision	1.0

TO : 客戶名稱

Date : 發行日期

HannStar Product Information

Model : HSD070IDW1-A**

Accepted by:

Signature

Date

Proposed by: Technical Service Division

Signature

Date

Note:1. Please contact HannStar Display Corp. before designing your product based on this module specification.

2.The information contained herein is presented merely to indicate the characteristics and performance of our products. No responsibility is assumed by HannStar for any intellectual property claims or other problems that may result from application based on the module described herein.

Document Title		Page No.	2/ 28
Document No.		Revision	1.0

Record of Revisions

Rev.	Date	Sub-Model	Description of change
1.0	發行日期		Preliminary Product Specification was first issued.

AmjackKala.com

Document Title		Page No.	3/ 28
Document No.		Revision	1.0

Contents

1.0	General description	p.4
2.0	Absolute maximum ratings	p.5
3.0	Optical characteristics	p.6
4.0	Block diagram	p.10
5.0	Interface pin connection	p.11
6.0	Electrical characteristics	p.13
7.0	Reliability test items.....	p.19
8.0	Outline dimension	p.20
9.0	Lot mark	p.21
10.0	Package specification	p.22
11.0	General precaution	p.23

Document Title		Page No.	4/ 28
Document No.		Revision	1.0

1.0 GENERAL DESCRIPTION

1.1 Introduction

HannStar Display model HSD070IDW1-A is a color active matrix thin film transistor (TFT) liquid crystal display (LCD) that uses amorphous silicon TFT as a switching device. This model is composed of a TFT LCD panel, a driving circuit and a back light system. This TFT LCD has a 7.0 (16:9) inch diagonally measured active display area with 2400 x 480 dot (800 horizontal by 480 vertical pixel) resolution.

1.2 Features

- 7 (16:9 diagonal) inch configuration
- 6 bits + FRC driver with 1channel TTL interface
- RoHS Compliance

1.3 Applications

- Mobile NB
- Digital Photo frame
- Multimedia applications and Others AV system

1.4 General information

Item	Specification	Unit
Outline Dimension	165.0 x 104.0 x 5.1 (Typ.)	mm
Display area	153.6(H) x 86.64(V)	mm
Number of Pixel	800 RGB(H) x 480(V)	pixels
Pixel pitch	0.192(H) x 0.1805(V)	mm
Pixel arrangement	RGB Vertical stripe	
Display mode	Normally white	
Surface treatment	Antiglare, Hard-Coating(3H) with EWV film	
Weight	(130) (Typ.)	g
Back-light	Single LED (Side-Light type)	
Power Consumption	B/L System (1.68)(Max.)	W

1.5 Mechanical Information

Item	Min.	Typ.	Max.	Unit	
Module Size	Horizontal(H)	164.7	165.0	165.3	mm
	Vertical(V)	103.7	104.0	104.3	mm
	Depth(D)	—	5.1	5.4	mm
Weight (Without inverter)	—	(130)	—	g	

Document Title		Page No.	5/ 28
Document No.		Revision	1.0

2.0 ABSOLUTE MAXIMUM RATINGS

2.1 Electrical Absolute Rating

2.1.1 TFT LCD Module

Item	Symbol	Min.	Max.	Unit	Note
Power supply voltage	V _{CC}	-0.3	5.0	V	GND=0
	V _{GH}	TBD	TBD	V	GND=0
	V _{GL}	TBD	TBD	V	GND=0
	AV _{DD}	TBD	TBD	V	AGND=0
	V _{COM}	TBD	TBD	V	
Logic Signal Input Level	V _I	-0.3	V _{CC} +0.3	V	

2.1.2 Back-Light Unit

Item	Symbol	Typ.	Max.	Unit	Note
LED current	I _L	140	—	mA	(1) (2)
LED voltage	V _L	9.9	12	V	(1) (2)(3)

Note

- (1) Permanent damage may occur to the LCD module if beyond this specification. Functional operation should be restricted to the conditions described under normal operating conditions.
- (2) Ta =25±2°C
- (3) Test Condition: LED current 140 mA

2.2 Environment Absolute Rating

Item	Symbol	Min.	Max.	Unit	Note
Operating Temperature	T _{opa}	-20	70	°C	
Storage Temperature	T _{stg}	-30	80	°C	

Document Title		Page No.	6/ 28
Document No.		Revision	1.0

3.0 OPTICAL CHARACTERISTICS

4. Optical specification

Item		Symbol	Condition	Min.	Typ.	Max.	Unit	Note
Contrast		CR	$\theta=0$	400	500	—		(1)(2)
Response time	Rising	T_R		—	5	7	msec	(1)(3)
	Falling	T_F		—	20	28		
White luminance (Center)		Y_L	Normal viewing angle	160	200	—	cd/m ²	(1)(4) ($I_L=140mA$)
Color chromaticity (CIE1931)	White	W_x		0.260	0.310	0.360		(1)(4)
		W_y	0.280	0.330	0.380			
Viewing angle	Hor.	θ_L	$CR>10$	TBD	70	—		
		θ_R		TBD	70	—		
	Ver.	θ_U		TBD	50	—		
		θ_D		TBD	60	—		
Brightness uniformity		B_{UNI}	$\theta=0$	70	—	—	%	(5)(7)
Optima View Direction		6 O' clock						(6)

4. Measuring Condition

- Measuring surrounding : dark room
- LED current I_L : 140mA
- Ambient temperature : $25\pm 2^\circ C$
- 15min. warm-up time.

4. Measuring Equipment

- FPM520 of Westar Display technologies, INC., which utilized SR-3 for Chromaticity and BM-5A for other optical characteristics.
- Measuring spot size : 20 ~ 21 mm

Document Title		Page No.	7/ 28
Document No.		Revision	1.0

Note (1) Definition of Viewing Angle :

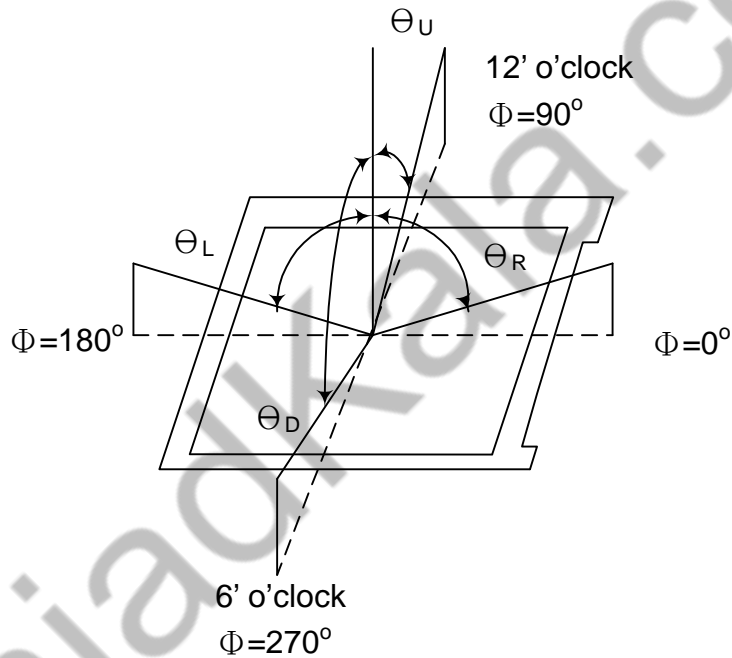

Note (2) Definition of Contrast Ratio(CR) :
measured at the center point of panel

$$CR = \frac{\text{Luminance with all pixels white}}{\text{Luminance with all pixels black}}$$

Document Title		Page No.	8/ 28
Document No.		Revision	1.0

Note (3) Definition of Response Time : Sum of T_R and T_F

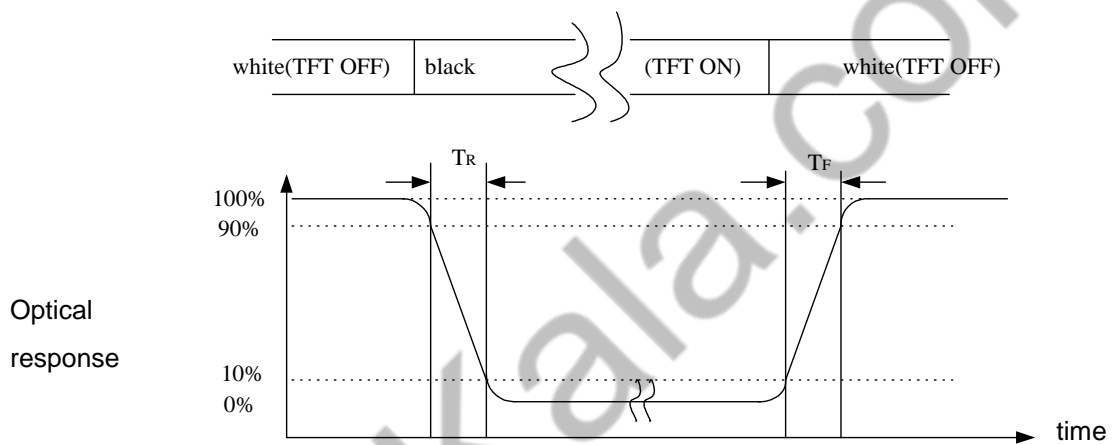

Note (4) Definition of optical measurement setup

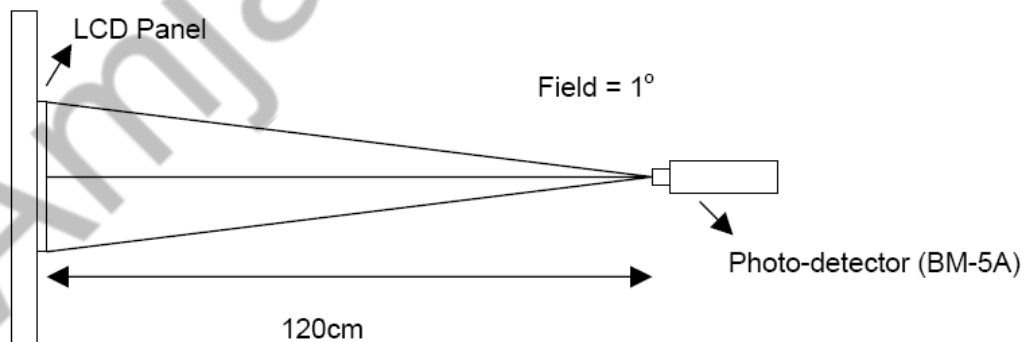

Document Title		Page No.	9/ 28
Document No.		Revision	1.0

Note (5) Definition of brightness uniformity

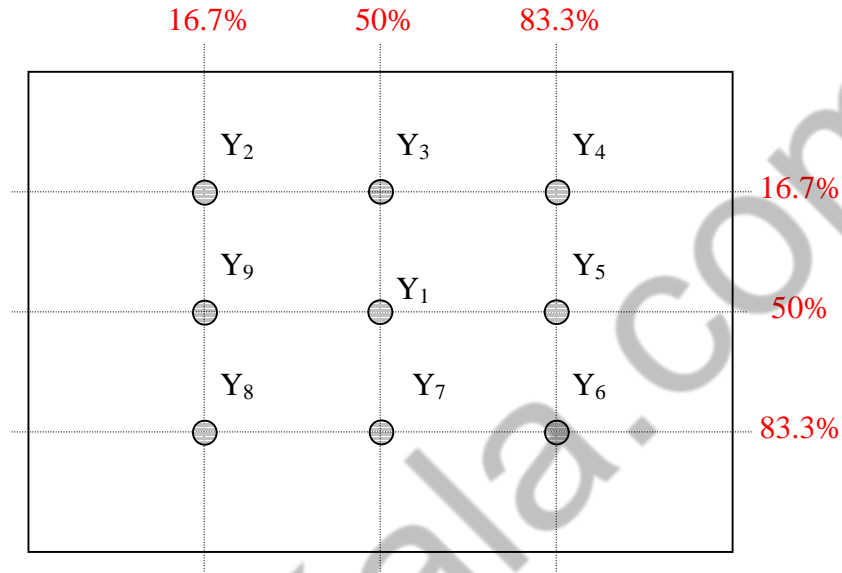

$$\text{Luminance uniformity} = \frac{(\text{Min Luminance of 9 points})}{(\text{Max Luminance of 9 points})} \times 100\%$$

Note (6) Rubbing Direction (The different Rubbing Direction will cause the different Optimal view direction.)

Note (7) Measured at the brightness of the panel when all terminals of LCD panel are electrically open.

Document Title		Page No.	10/ 28
Document No.		Revision	1.0

4.0 BLOCK DIAGRAM

4.1 TFT LCD Module

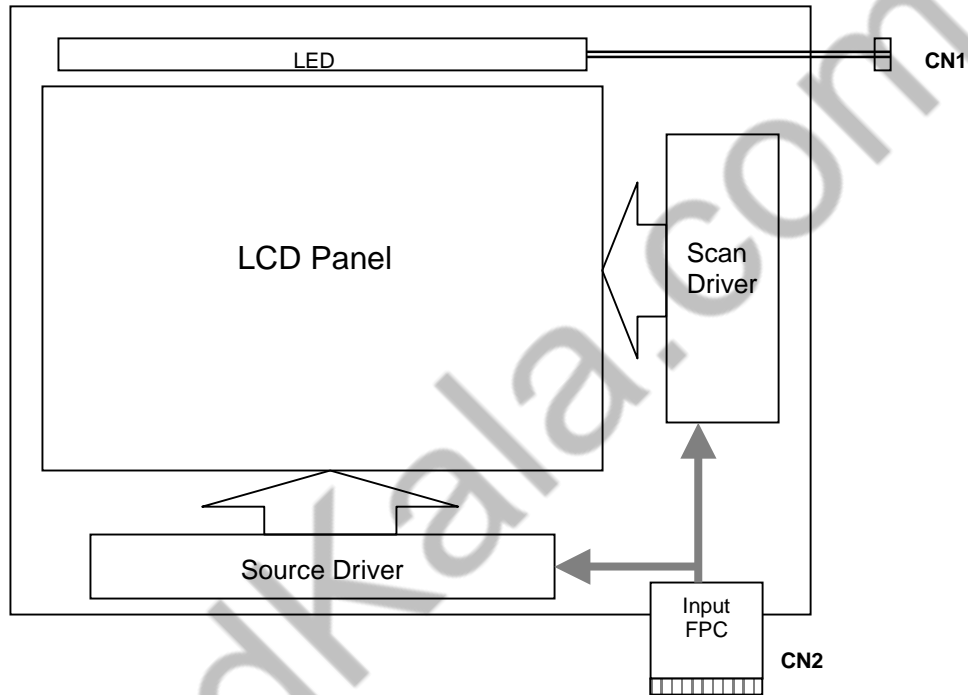

4.2 Pixel Format

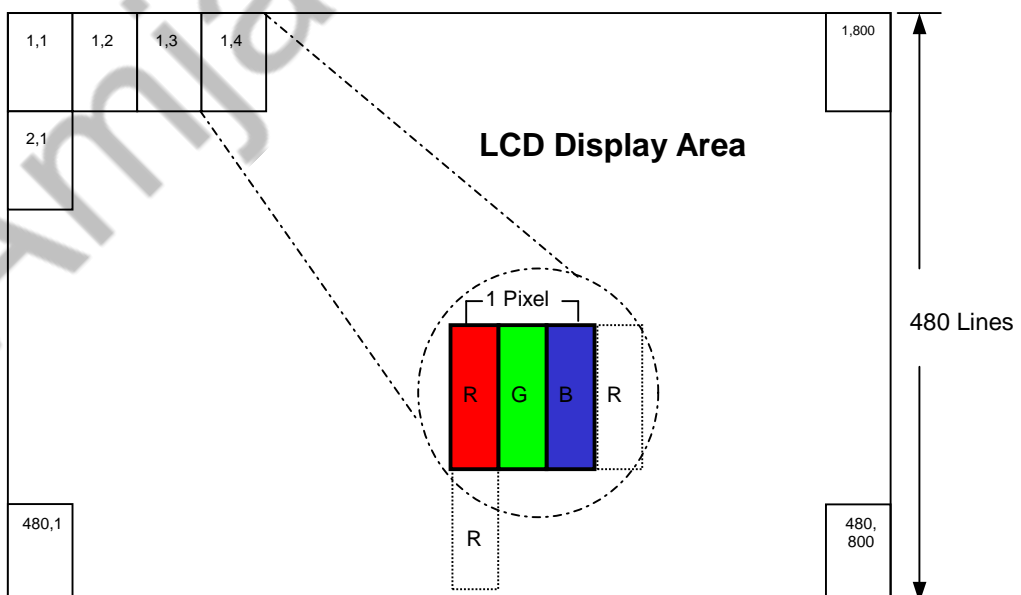

Document Title		Page No.	11/ 28
Document No.		Revision	1.0

5.0 INTERFACE PIN CONNECTION

5.1 TFT LCD Module

CN2 (Input signal): FPC Down Connector, (FH28-60S-0.5SH (HIROSE),60pin,pitch = 0.5mm)

Terminal no.	Symbol	I/O	Function
1	AGND	P	Analog Ground
2	AVDD	P	Analog Power
3	VCC	P	Digital Power
4	R0	I	Data Input(LSB)
5	R1	I	Data Input
6	R2	I	Data Input
7	R3	I	Data Input
8	R4	I	Data Input
9	R5	I	Data Input
10	R6	I	Data Input
11	R7	I	Data Input(MSB)
12	G0	I	Data Input(LSB)
13	G1	I	Data Input
14	G2	I	Data Input
15	G3	I	Data Input
16	G4	I	Data Input
17	G5	I	Data Input
18	G6	I	Data Input
19	G7	I	Data Input(MSB)
20	B0	I	Data Input(LSB)
21	B1	I	Data Input
22	B2	I	Data Input
23	B3	I	Data Input
24	B4	I	Data Input
25	B5	I	Data Input
26	B6	I	Data Input
27	B7	I	Data Input(MSB)

Document Title		Page No.	12/ 28
Document No.		Revision	1.0

28	DCLK	I	Clock input
29	DE	I	Data Enable signal
30	HSD	I	Horizontal sync input.Negative polarity
31	VSD	I	Vertical sync input.Negative polarity
32	MODE3	I	DE/SYNC mode select .normally pull high H:DE mode.L:HSD/VSD mode
33	RSTB	I	global reset pin.Active low to enter reset state.suggest to connecting with an RC reset circuit for stability .normally pull high.
34	STBYB	I	standby mode,normally pull high STBYB="1",normal operation STBYB="0",timming control ,sorce driver will turn off,all output are high-Z
35	SHLR	I	Source right or left sequence control.SHLR="L",shift left:last data=S1<-S2...S1200=first data SHLR="H",shift right:first data=S1->SS2...S1200=last data

Document Title		Page No.	13/ 28
Document No.		Revision	1.0

Terminal no.	Symbol	I/O	Function
36	VCC	P	Digital Power
37	UPDN	I	Shift up or down control. UPDN= "H", up shift: STVD (Input) → G1 ~ G480 →STVU (Output) UPDN = "L", down shift: STVU (Input) →G480 ~ G1 →STVD (Output)
38	GND	P	Digital Ground
39	AGND	P	Analog Ground
40	AVDD	P	Analog Power
41	VCOMin	I	For external VCOM DC input(Optional)
42	DITH	I	Dithering setting DITH="H" 6bit resolution (last 2 bits of input data truncated) DITH="L" 8bit resolution (default setting)
43	NC	-	Not connect
44	NC	-	Not connect
45	V10	P	Gamma correction voltage reference
46	V9	P	Gamma correction voltage reference
47	V8	P	Gamma correction voltage reference
48	V7	P	Gamma correction voltage reference
49	V6	P	Gamma correction voltage reference
50	V5	P	Gamma correction voltage reference
51	V4	P	Gamma correction voltage reference
52	V3	P	Gamma correction voltage reference
53	V2	P	Gamma correction voltage reference
54	V1	P	Gamma correction voltage reference
55	NC	-	Not connect
56	VGH	P	Positive Power for TFT
57	VCC	P	Digital Power

Document Title		Page No.	14/ 28
Document No.		Revision	1.0

58	VGL	P	Negative Power for TFT
59	GND	P	Digital Ground
60	NC	-	Not connect

5.2 Back-Light Unit

CN1 LED Power Source Molex 51021-200

Mating Connector: Aces 85204-02001

Terminal no.	Symbol	Function
1	VL	LED power supply (high voltage)
2	GL	LED power supply (low voltage)

Document Title		Page No.	15/ 28
Document No.		Revision	1.0

6.0 ELECTRICAL CHARACTERISTICS

6.1 TFT LCD Module

Item	Symbol	Min.	Typ.	Max.	Unit	Note
Supply Voltage	V _{CC}	3.2	3.3	3.6	V	
	V _{GH}	TBD	15	TBD	V	
	V _{GL}	TBD	-7	TBD	V	
	A _{VDD}	TBD	11.6	TBD	V	
V _{COM}	V _{CDC}	-	TBD	-	V	
Input signal voltage	V _{iH}	0.7 V _{CC}	-	V _{CC}	V	Note (1)
	V _{iL}	0	-	0.3 V _{CC}	V	
Current of power supply	I _{DD}	-	TBD	-	uA	V _{CC} =3.3V
	I _{ADD}	-	TBD	-	mA	A _{VDD} =11.6V(Black)
	I _{GH}	-	TBD	-	uA	V _{GH} =15V
	I _{GL}	-	TBD	-	uA	V _{GL} = 7V
Input level of V1~V5	V _X	-	TBD	-	V	
Input level of V6~V10	V _X	-	TBD	-	V	

Note (1): HSYNC , VSYNC , DE , Digital Data

Note (2): Be sure to apply the power voltage as the power sequence spec.

Note (3): DGND=AGND=0V,)

Document Title		Page No.	16/ 28
Document No.		Revision	1.0

6.2 Back-Light Unit

The back-light system is an edge-lighting type with 21 LED.

The characteristics of the LED is shown in the following tables.

Item	Symbol	Min.	Typ.	Max.	Unit	Note
LED current	IL	—	140	—	mA	
LED voltage	VL	—	9.9	12	V	
Operating LED life time	Hr	20,000	—	—	Hour	(1)

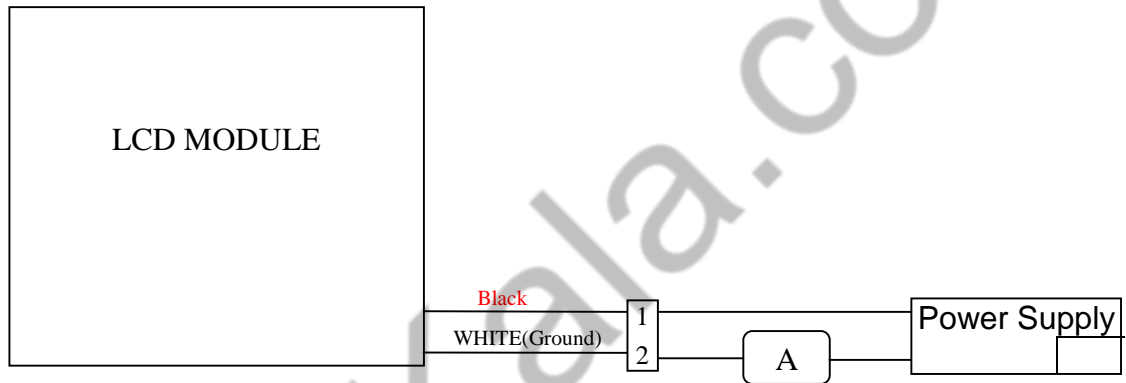

Note (1) LED life time (Hr) can be defined as the time in which it continues to operate under the condition : $T_a=25\pm 3^\circ\text{C}$, typical IL value indicated in the above table until the brightness becomes less than 50%.

Document Title		Page No.	17/ 28
Document No.		Revision	1.0

6.3 AC Characteristics

Item	Symbol	Min.	Typ.	Max.	Unit	Note
DCLK cycle time	Tcph	25			ns	
DCLK frequency	fclk		33	40	MHz	
DCLK pulse duty	Tcwh	40	50	60	%	
VSD setup time	Tvst	8			ns	
VSD hold time	Tvhd	8			ns	
HSD setup time	Thst	8			ns	
HSD hold time	Thhd	8			ns	
Data setup time	Tdsu	8			ns	
Data hold time	Tdhd	8			ns	
DE setup time	Tesu	8			ns	
DE hold time	Tehd	8			ns	
Horizontal display area	thd		800		Tcph	
HSD period time	th		928		Tcph	
HSD pulse width	thpw	1	48		Tcph	
HSD back porch	thb		40		Tcph	
HSD front porch	thfp		40		Tcph	
Vertical display area	tvd		480		th	
VSD period time	tv		525		th	
VSD pulse width	tvpw		3		th	
VSD back porch	tvb		29		th	
VSD front porch	tvfp		13		th	

Document Title		Page No.	18/ 28
Document No.		Revision	1.0

6.4 Timing Diagram of Interface Signal

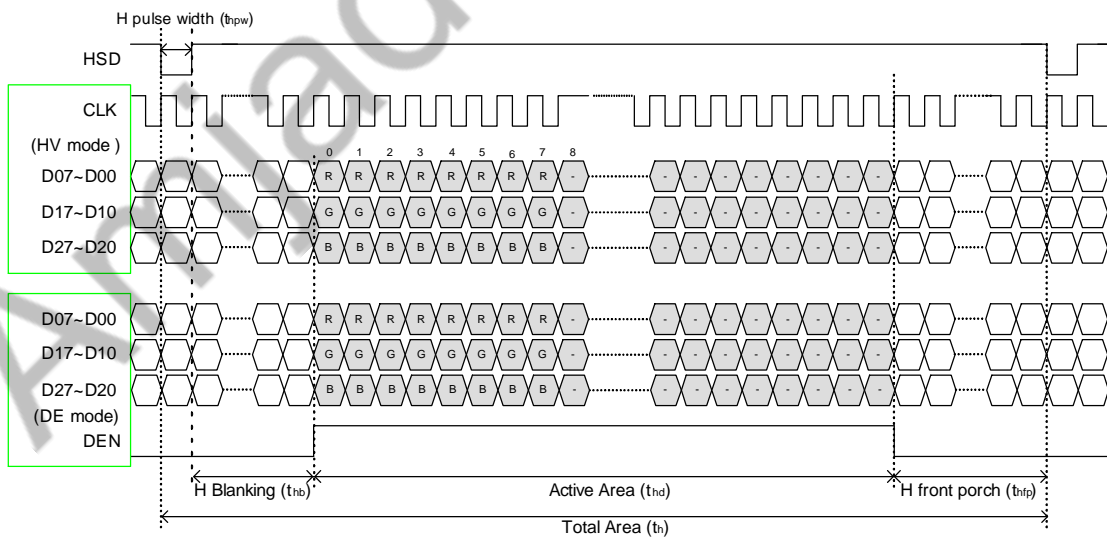
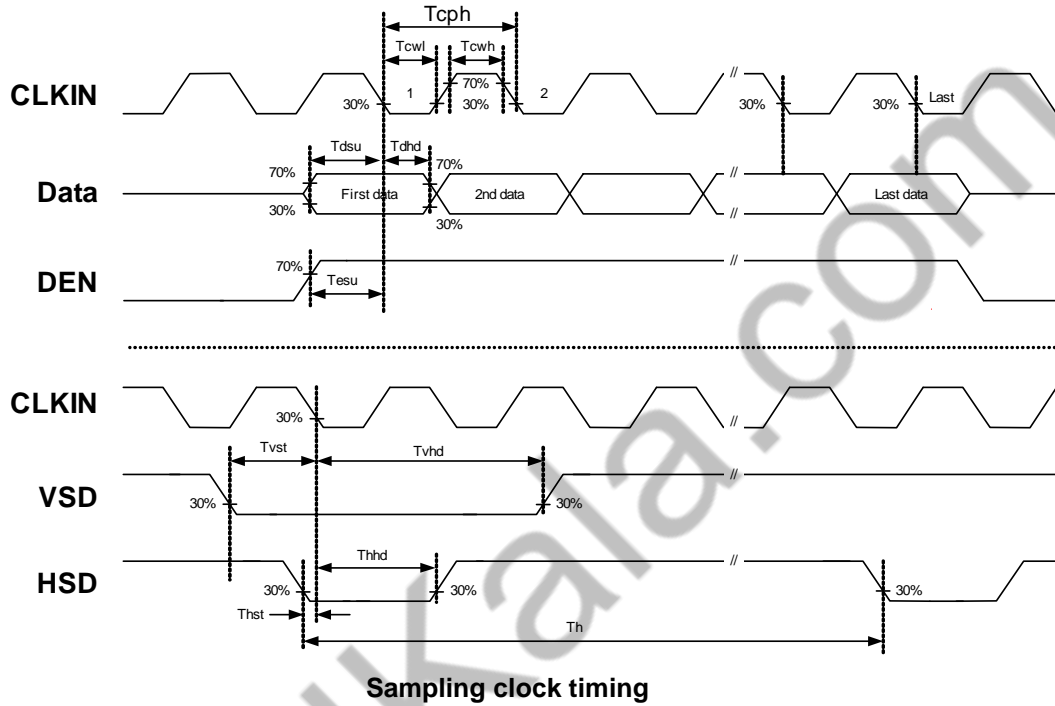

Horizontal display timing range

Document Title		Page No.	19/ 28
Document No.		Revision	1.0

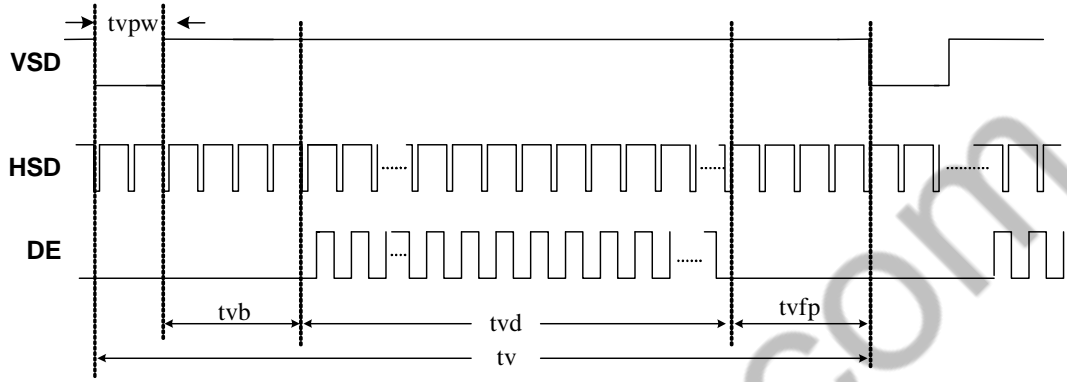

Vertical timing

AmjadKala.com

Document Title		Page No.	20/ 28
Document No.		Revision	1.0

6.5 Power Sequence

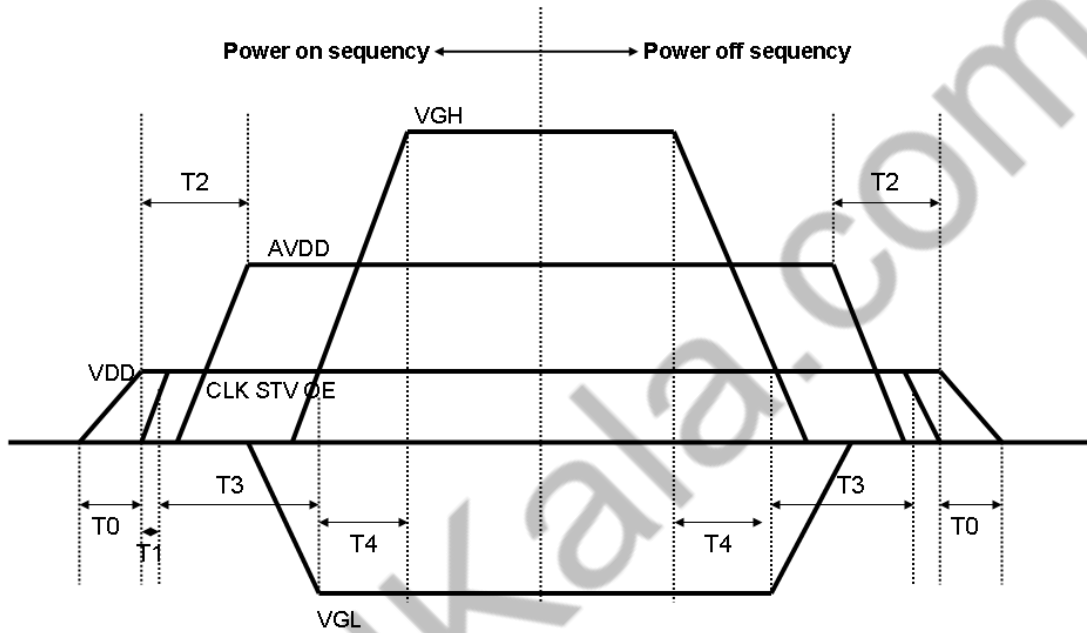

- T0 < 20 ms
- T1 > 100us
- T2 > 16 ms
- T3 > 20 ms
- T4 > 10 ms

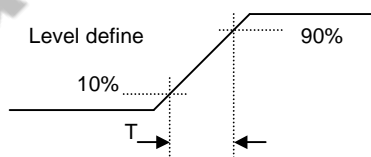

Power On Sequence: V_{DD} -> AVDD -> VGL -> VGH
 Power Off Sequence: VGH -> VGL -> AVDD -> V_{DD}

Document Title		Page No.	21/ 28
Document No.		Revision	1.0

7.0 Reliability test items

No.	Item	Conditions	Remark
1	High Temperature Storage	Ta=+80°C, 240hrs	
2	Low Temperature Storage	Ta=-30°C, 240hrs	
3	High Temperature Operation	Ta=+70°C, 240hrs	
4	Low Temperature Operation	Ta=-20°C, 240hrs	
5	High Temperature and High Humidity (operation)	Ta=+60°C, 90%RH, 240hrs	
6	Thermal Cycling Test (non operation)	-30°C(30min) → +80°C(30min), 200cycles	
7	Electrostatic Discharge	±200V,200pF(0Ω) 1 time/each terminal	
8	Vibration	1.Random: 1.04Grms, 10~500Hz, X/Y/Z, 30min/each direction 2.Sweep sine: 1.5G, 5~500Hz, X/Y/Z, 30min/each direction	
9	Shock	100G,6ms, ±X, ±Y, ±Z 3 time for each direction	JIS C7021, A-10 (Condition A)
10	Vibration (with carton)	Random: 1.04Grms, 10~500Hz, X/Y/Z 45min/each direction Fixed: 5Hz, 1.5Grms, X/Y/Z 45min/each direction	
11	Drop (with carton)	Height: 60cm 1 corner, 3 edges, 6 surfaces	JIS Z0202

Note: There are no display function NG issue occurred, All the cosmetic specification is judged before the reliability stress.

Document Title		Page No.	22/ 28
Document No.		Revision	1.0

8.0 OUTLINE DIMENSION
6.1 Outline Dimension

Unit : mm

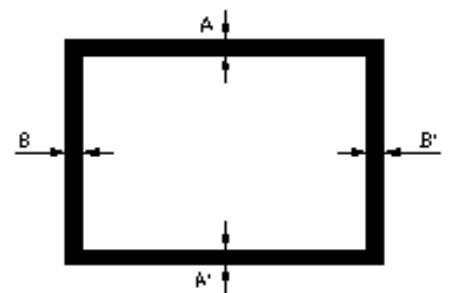
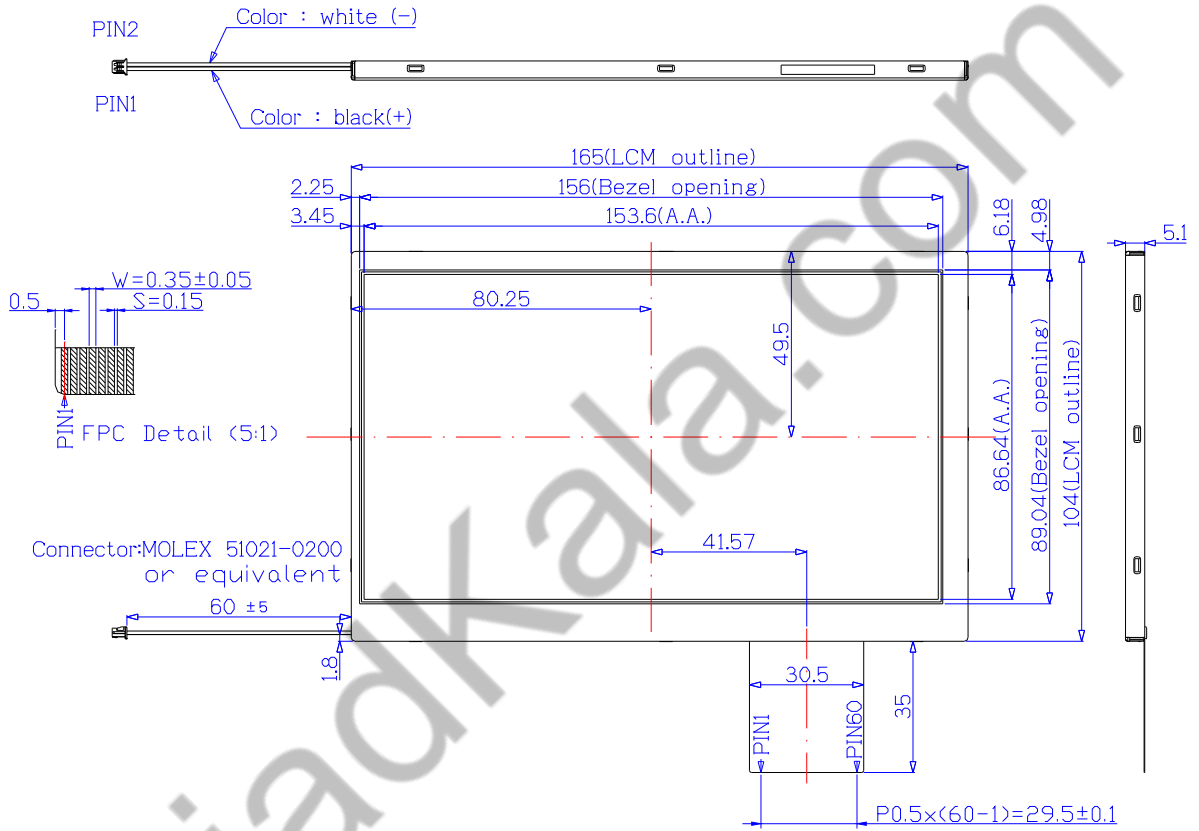

<P> BM 寬縱向 | A-A' |

<Q> BM 寬橫向 | B-B' |

Document Title		Page No.	23/ 28
Document No.		Revision	1.0

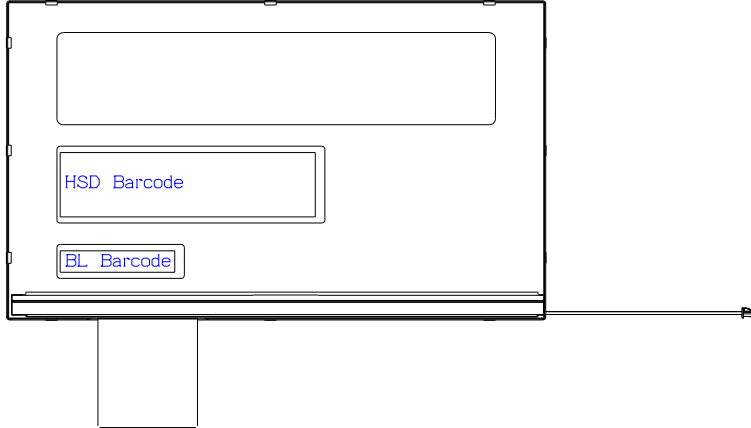

Note : 1.General tolerance : +/- 0.3mm

AmjadKala.com

Document Title		Page No.	24/ 28
Document No.		Revision	1.0

9.0 LOT MARK

8.1 Lot Mark

1	2	3	4	5	6	7	8	9	10	11	12	13	14	15
---	---	---	---	---	---	---	---	---	----	----	----	----	----	----

code 1,2,3,4,5,6: HannStar internal flow control code.

code 7: production location.

code 8: production year.

code 9: production month.

code 10,11,12,13,14,15: serial number.

Note (1) Production Year

Year	1999	2000	2001	2002	2003	2004	2005	2006	2007	2008
Mark	9	0	1	2	3	4	5	6	7	8

Note (2) Production Month

Month	Jan.	Feb.	Mar.	Apr.	May.	Jun.	Jul.	Aug.	Sep.	Oct	Nov.	Dec.
Mark	1	2	3	4	5	6	7	8	9	A	B	C

8.2 Location of Lot Mark

- (1) The label is attached to the backside of the LCD module.
- (2) This is subject to change without prior notice.

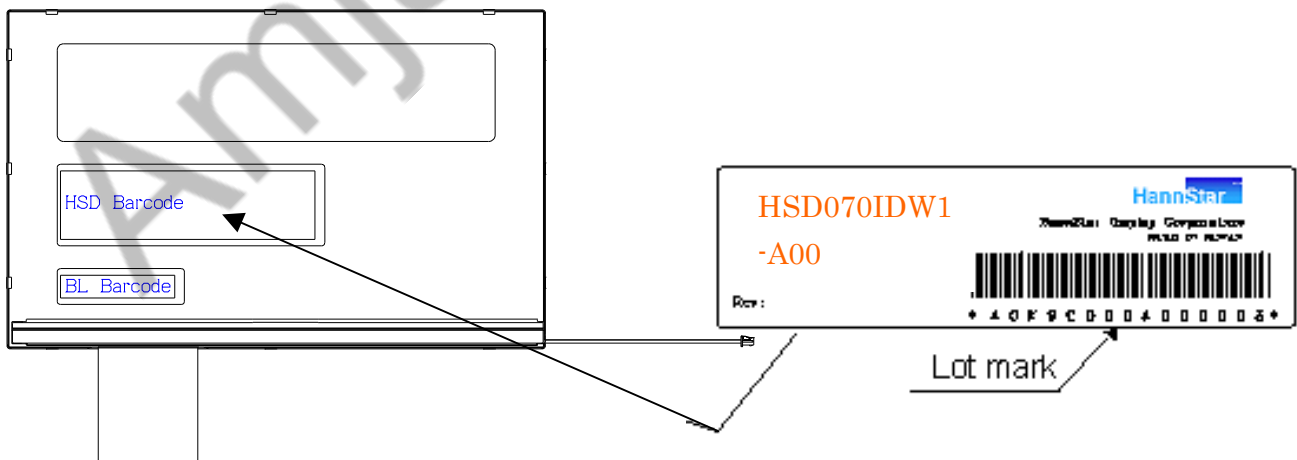

Document Title		Page No.	25/ 28
Document No.		Revision	1.0

10.0 PACKAGE SPECIFICATION

9.1 packing form

- (1) Package quantity in one carton: 60 pieces.
- (2) Carton size: 464±3 mm×360±3 mm×370±3 mm.
- (3) For domestic transportation only.

9.2 packing assembly drawings

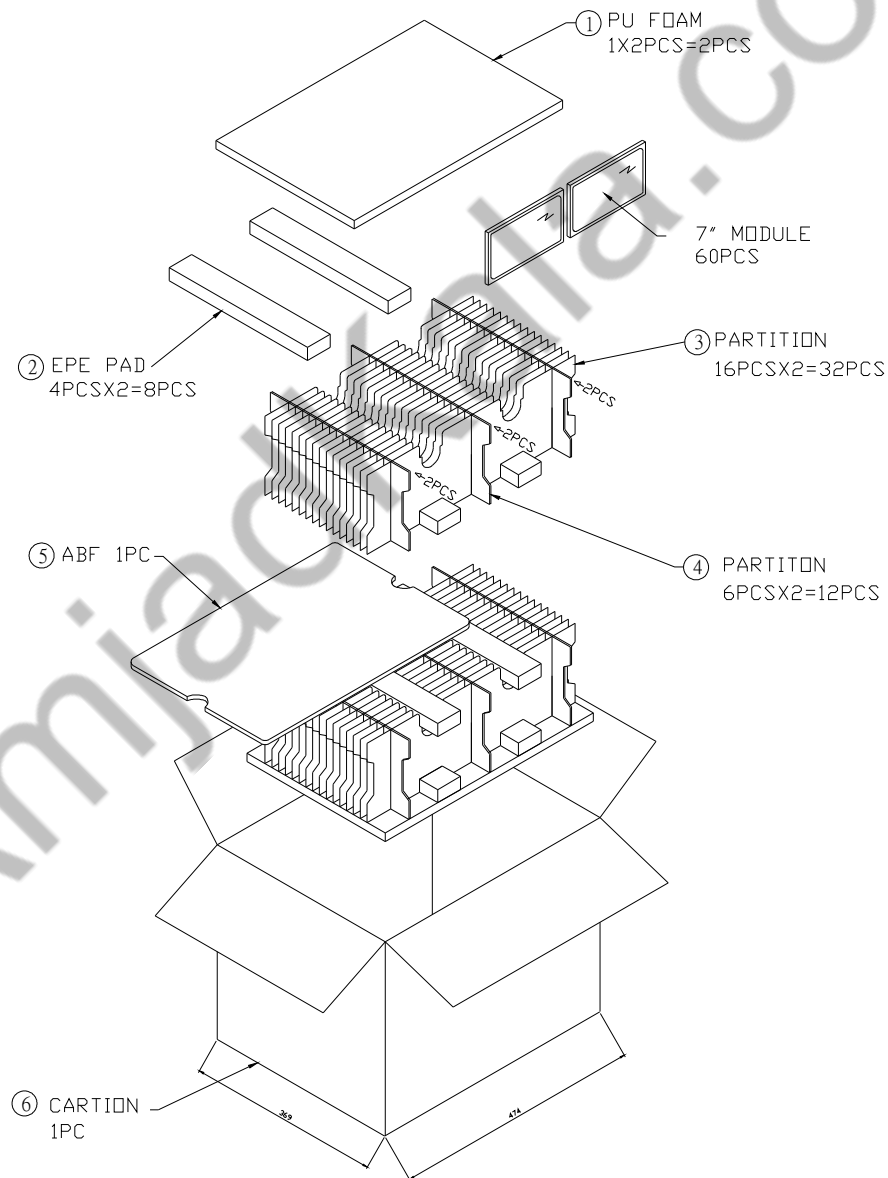



Document Title		Page No.	26/ 28
Document No.		Revision	1.0

AmjadKala.com

Document Title		Page No.	27/ 28
Document No.		Revision	1.0

11.0 GENERAL PRECAUTION

10.1 Use Restriction

This product is not authorized for use in life supporting systems, aircraft navigation control systems, military systems and any other application where performance failure could be life-threatening or otherwise catastrophic.

10.2 Disassembling or Modification

Do not disassemble or modify the module. It may damage sensitive parts inside LCD module, and may cause scratches or dust on the display. HannStar does not warrant the module, if customers disassemble or modify the module.

10.3 Breakage of LCD Panel

- 11.3.1. If LCD panel is broken and liquid crystal spills out, do not ingest or inhale liquid crystal, and do not contact liquid crystal with skin.
- 11.3.2. If liquid crystal contacts mouth or eyes, rinse out with water immediately.
- 11.3.3. If liquid crystal contacts skin or cloths, wash it off immediately with alcohol and rinse thoroughly with water.
- 11.3.4. Handle carefully with chips of glass that may cause injury, when the glass is broken.

10.4 Electric Shock

- 11.4.1. Disconnect power supply before handling LCD module.
- 11.4.2. Do not pull or fold the LED cable.
- 11.4.3. Do not touch the parts inside LCD modules and the fluorescent LED's connector or cables in order to prevent electric shock.

10.5 Absolute Maximum Ratings and Power Protection Circuit

- 11.5.1. Do not exceed the absolute maximum rating values, such as the supply voltage variation, input voltage variation, variation in parts' parameters, environmental temperature, etc., otherwise LCD module may be damaged.
- 11.5.2. Please do not leave LCD module in the environment of high humidity and high temperature for a long time.
- 11.5.3. It's recommended to employ protection circuit for power supply.

10.6 Operation

- 11.6.1 Do not touch, push or rub the polarizer with anything harder than HB pencil lead.
- 11.6.2 Use fingerstalls of soft gloves in order to keep clean display quality, when persons handle the LCD module for incoming inspection or assembly.
- 11.6.3 When the surface is dusty, please wipe gently with absorbent cotton or other soft material.

Document Title		Page No.	28/ 28
Document No.		Revision	1.0

11.6.4 Wipe off saliva or water drops as soon as possible. If saliva or water drops contact with polarizer for a long time, they may causes deformation or color fading.

11.6.5 When cleaning the adhesives, please use absorbent cotton wetted with a little petroleum benzine or other adequate solvent.

10.7 Mechanism

Please mount LCD module by using mouting holes arranged in four corners tightly.

10.8 Static Electricity

11.8.1 Protection film must remove very slowly from the surface of LCD module to prevent from electrostatic occurrence.

11.8.2. Because LCD module use CMOS-IC on circuit board and TFT-LCD panel, it is very weak to electrostatic discharge. Please be careful with electrostatic discharge.

Persons who handle the module should be grounded through adequate methods.

10.9 Strong Light Exposure

The module shall not be exposed under strong light such as direct sunlight. Otherwise, display characteristics may be changed.

10.10 Disposal

When disposing LCD module, obey the local environmental regulations.